

# UCG 35 - 12

12V 35AH

AGM GEL

# Ultracell®

'Quality in Every Language'

Image



Terminal Type

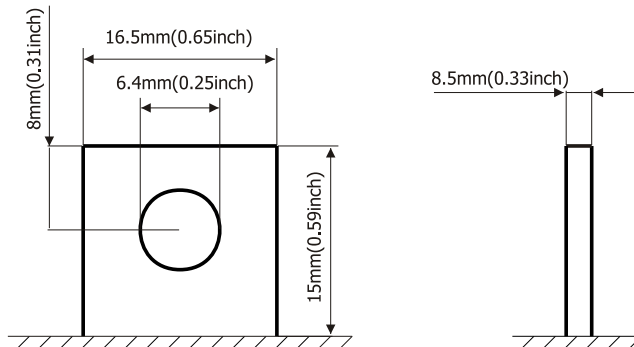

Dimensions

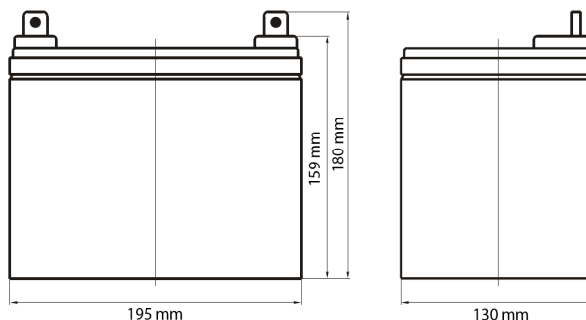
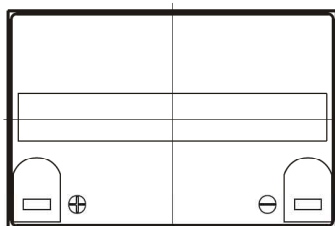

Specifications

Battery Model	UCG 35 - 12			
Designed Floating Life	10 Years			
Capacity (25°C)	20HR (1.65A, 1.75V)	10HR (3.14A, 1.75V)	5HR (5.61A, 1.75V)	1HR (19.8A, 1.75V)
	35AH	33.3AH	28.1AH	19.8AH
Dimensions	Length	Width	Height	Total Height
	195mm	130mm	159mm	180mm
Approx. Weight	11.5Kg			
Internal Resistance	Fully Charged at 25°C 0.010hm			
Self Discharge	3% of capacity declined per month at 25°C			
Capacity Affected by Temperature	40°C	25°C	0°C	-15°C
	102%	100%	85%	65%
Charge Voltage (25°C)	Cycle Use		Float Use	
	14.4-15V (-30mV/C), max. Current: 8.3A		13.6-13.8V (-20mV/C)	

Construction

Component ——— Raw material  
 Positive ——— Lead dioxide  
 Negative ——— Lead  
 Container ——— ABS (Flame Retardent optional)  
 Cover ——— ABS (Flame Retardent optional)

*Sealed and maintenance free option*

Sealant ——— Epoxy Resin  
 Safety Valve ——— EPDR  
 Terminal ——— Copper  
 Separator ——— Fibre Glass  
 Electrolyte ——— Sulphuric acid and Gel

*Non-spillable construction design*



CE 1188



MH 29410

Tel | +44 (0) 151 523 2777  
 Fax | +44 (0) 151 523 0855  
 E-mail | info@ultracell.co.uk  
 Web | www.ultracell.co.uk

### Charge Characteristic

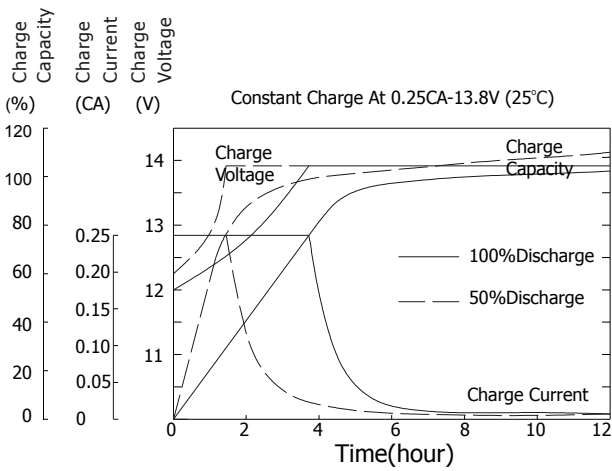

### Discharge Characteristic 25°C

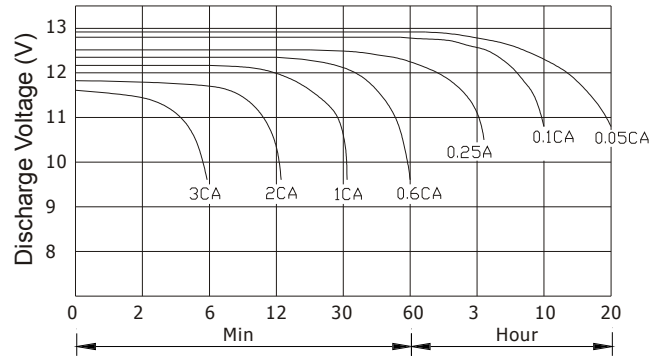

### Relationship of OCV and state of charge

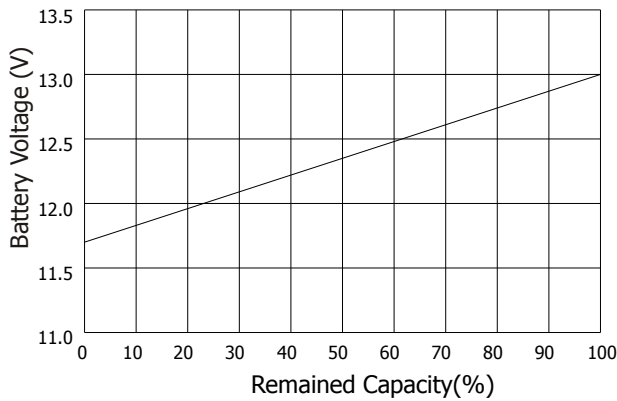

### Life Expectancy Cycle Use:

- 100% depth of discharge 350 cycles
- 80% depth of discharge 600 cycles
- 50% depth of discharge 900 cycles
- 30% depth of discharge 1500 cycles
- 20% depth of discharge 1700 cycles

### Constant Current Discharge Ratings - amperes at 25°C

F.V / Time	5 MIN	10 MIN	15 MIN	30 MIN	1 HR	3 HR	5 HR	10 HR	20 HR
1.60 V	130.02	79.86	60.52	36.89	19.8	10.3	6.07	3.37	1.84
1.67 V	120.78	76.56	58.67	35.38	19.6	8.71	5.94	3.30	1.78
1.70 V	111.54	73.26	56.83	32.08	18.9	8.29	5.81	3.23	1.78
1.75 V	110.22	71.28	54.98	30.56	18.5	8.05	5.64	3.18	1.67
1.80 V	97.68	67.98	49.62	28.31	17.2	7.85	5.54	3.15	1.65
1.85 V	86.46	64.55	44.75	25.94	16.7	7.72	5.54	2.45	1.65

### Constant Power Discharge Ratings - watts at 25°C

F.V / Time	5 MIN	10 MIN	15 MIN	30 MIN	1 HR	3 HR	5 HR	10 HR	20 HR
1.60 V	264	171.60	110	76.6	42.9	16.7	11.4	6.40	3.37
1.67 V	255.42	167.64	130.02	75.2	42.4	16.6	11.3	6.40	3.37
1.70 V	244.86	165	126.72	73.9	42	16.5	11.3	6.34	3.30
1.75 V	23.34	158.40	122.76	71.9	41.3	16.4	11.2	6.34	3.30
1.80 V	199.98	146.52	117.48	70	40	16.1	11.1	6.20	3.23
1.85 V	188.76	135.96	112.20	66.7	39.1	15.8	11.0	6.20	3.23



Tel +44 (0) 151 523 2777  
 Fax +44 (0) 151 523 0855  
 E-mail info@ultracell.co.uk  
 Web www.ultracell.co.uk